

W2BC: A Proposal for a Converged Baseband Implementation of WiMax and WiFi Transceivers

Ali Al-Sherbaz* and Ihsan Lami**

*School of Science & Technology, The University of Northampton, NN2 6JD, UK, Ali.Al-Sherbaz@northampton.ac.uk

**Applied Computing Dept., The University of Buckingham, MK18 1EG, UK, ihsan.lami@buckingham.ac.uk

Article Info

Article history:

Received Oct 20th, 2012

Accepted Nov 5th, 2012

Keyword:

Convergence

WiMax

WiFi

Baseband

ABSTRACT

There have been many attempts to converge wireless teraservers functionality and implementation at various layers. The approach of this work is to explore the similarities of the OFDM signals, as used in WiMax and WiFi, to converge their baseband implementation at the physical layer. The proposed W2BC solution reduces implementation complexity, size, power, and cost, while preserving signal and communication integrity for standalone WiMax and WiFi functionality. This paper reviews the convergence approaches that lead to the proposed W2BC implementation, explain the mathematical derivation, describe the simulation model and discuss the test results for real-world usage scenarios.

Copyright © 2013 Institute of Advanced Engineering and Science.
All rights reserved.

Corresponding Author:

Dr. Ihsan Lami,
Applied Computing Dept.,
School of Science, Medicine and Dentistry,
The University of Buckingham,
Buckingham MK18 1EG, UK,
Email: ihsan.lami@buckingham.ac.uk

1. INTRODUCTION

The objective of this paper is to describe a new convergence method for integrating WiMax and WiFi baseband functions at the physical layer (PHY). The novelty of this convergence is centered on making these baseband functions reconfigurable to serve WiMax or WiFi signals, thus reducing the overheads of having side-by-side implementations of these two technologies.

The motivation behind this study was to investigate the best technique to combine WiFi and WiMax signals so to utilise the "baseband implementation chain" to handle both of these technologies. Thus, saving device cost, size, power and implementation complexity by using the same baseband process instead of the current side-by-side implementations for these two technologies. This saving shall enhance the availability of data-centric wireless technologies in commercial products, where any user can have both WiFi and WiMax services available without having to switch between these services. This offers other benefits such VoIP, simplified data provisioning, easier management, less maintenance, fewer interface, fast provisioning, newer and improved services, and easy user interface. Convergence technologies are also reviewed in this paper including their advantages and the impediments in their implementation methods. This review shall focus on the WiFi, WiMax and the "Media-independent handover" (or IEEE 802.21) technologies.

The proposed W2BC does not suggest changing the standard itself, but instead, to combine the functions of the two WiMax and WiFi implementations into one Baseband PHY implementation using Software Defined Radio (SDR) concept [1]. Therefore, by using software controlled by the application layer to switch the PHY functions from one technology signals to the other.

2. Review of Wireless Technologies Convergence Approaches

The convergence of wireless communications technologies has been taking the centre stage of research recently. This is an ever growing and expanding theme. The focal point of this paper is to investigate the possibilities of combining different wireless standards, focusing on WiMax and WiFi for the implementation and testing. The commercial importance and integration of 802.11 and 802.16 into one WiMax/ WiFi/module has also been discussed extensively in the following publications [2], [3], [4], and [5] all of which propose approaches for the realization of an internetworking between these two standards, as well as with cellular technologies for 3.5G services.

The authors have concluded that exploring the similarities and dissimilarities among the WiMax and WiFi standards is the initial step towards the convergence. The major similarities are in the adopted OFDM transmission techniques and in the digital modulation types (BPSK, QPSK, 16QAM and 64QAM). The convergence can be done in any layer among the seven OSI layers and the easiest way is to choose upper layers convergence because it can be easily implemented by software; however experience from such convergence has shown that more delay and jitter will be resulted. Consequently, to illuminate these problems, a lower layer (MAC and PHY) convergence is more appropriate.

There are two camp activities in wireless convergence based on OFDM. One camp focuses on consolidating the protocols to adopt both WiMax and WiFi data, while the other camp focuses on consolidating the implementation of the transceiver on silicon. Table (1) shows two categories of approaches for WiMAX-WiFi Convergence.

Table 1, WiMax-WiFi Convergence Comparison

WiMax-WiFi Convergence's approaches						
	Implementation Approaches			Protocol Approaches		
	W2BC	IP Reuse	Third Party Bridge	Create a New Wireless Standard	WiMax Standard Amendment	WiFi Standard Amendment
Description	Single baseband PHY layer serves Both WiFi and WiMax	Technique for high-level IP proposed by MIT - Nokia	Dual PHY/RF hardware Single Chip-Intel	IEEE 802.21 Media Independent Handover Services	IEEE 802.16.4 Wireless HUMAN	IEEE 802.11u internetworking with external networks
Proposed Date	Q1-2008	Q2-2007	Q2-2006	Q3-2002	Q1-2004	Q4-2004
Approval Date	-	-	-	Q4-2008	Q3-2009	Q3-2010
Commercial Deployment			Dual BB	tba	tba	tba
Interoperability Test (IOT) / Trails	Passes All Simulation	Verified to RTL stage	Done	On-Going	Scheduled	On-going

The proposed W2BC fits in the “implementational approaches” category, and its mathematical derivation and testing is described in the next two sections. [1] is an example of an “IP Reuse” approach where a library of low level PHY functions are available to be utilised by both WiMax and WiFi implementation. i.e. these “Register Transfer Level” functions are shared between the two technologies at the Verilog design process. The “Third Party Bridge” approaches use a MAC layer bridge to link dual PHY implementations [6]. The “Protocol Approaches” category includes the convergence attempts at the IEEE Standards specification: the emerging IEEE standard 802.21 for media-independent handover services will support seamless mobility between IEEE 802.11 and IEEE 802.16, by integrating the two radio access technologies into one system [7]. The proposed IEEE 802.16.4 standard will be based on modifications of the IEEE 802.16 MAC layer so to implement the PHY layer with the IEEE 802.11a as well as other standards, [8]. Finally for Table (1), the proposal for the IEEE 802.11u is to enhance the MAC layer to allow higher layer convergence with external networks based on other technologies [9], [10].

3. Mathematical Derivation for the W2BC

As detailed in the IEEE standard of WiFi [11] and WiMax [12], both technologies use the orthogonal frequency division multiplexing (OFDM) transmission techniques and the same digital modulation types (BPSK, QPSK, 16QAM and 64 QAM). Therefore, convergence at the PHY layer shall significantly reduce the base-station/handset cost, size, power and complexity. i.e. same silicon block is used for both technologies. Also, controlling the signal selection of the convergence at the PHY layer may increase the complexity of the baseband chip [13], especially when this control can be easily implemented by software at the application layer.

3.1 WiMax-WiFi OFDM Signal Description

The IEEE 802.11a and 802.11n WiFi standards have 2.4GHz or 5GHz carrier centre frequencies respectively, while the IEEE 802.16 WiMax OFDM-TDD standard has a 3.5GHz carrier centre frequency. The WiMax-OFDM number of symbols (N_{FFT}) is 256 and the WiFi-OFDM N_{FFT} is 64. To harmonize this mismatch in N_{FFT} , W2BC allow configuration of the baseband blocks.

In General, any OFDM signal, $S(t)$, irrespective of its centre frequency, bandwidth or samples number, can be represented by equation (1), [12]. This equation underpins the design of the proposed W2BC.

$$S(t) = \text{Re} \left\{ e^{j2\pi f_c t} \cdot \sum_{\substack{k=-N_{used}/2 \\ k \neq 0}}^{N_{used}/2} C_k \cdot e^{j2\pi k \Delta f (t-T_g)} \right\} \quad 1)$$

Where,

N_{used} is the Number of used subcarriers, $N_{used} = 200$ for WiMax & $N_{used} = 52$ for WiFi,

C_k is the I-Q complex numbers representing the Data,

Δf is the subcarriers frequency spacing, $\Delta f = 15.625$ KHz for WiMax & $\Delta f = 312.5$ KHz for WiFi,

f_c is the carrier centre frequency,

T_g is the Guard Time, $T_g = 8.0 \mu s$ for WiMax & $T_g = 0.8 \mu s$ for WiFi

Mathematically, equation (1) consists of three main parts:

- The Carrier signal $e^{j2\pi f_c t}$ at f_c , where f_c is the factor for deciding which technology is being used.
- The transmitted Data C_k , where k is the “subcarriers frequency offset index” for one sample.
- The Subcarriers signals $e^{j2\pi k \Delta f (t-T_g)}$, where one symbol is equal to the summation of the N_{FFT} samples of the orthogonal subcarriers.

3.2 W2BC - Mathematical Derivation

Figure (1) is a block diagram representing the functions of the WiMax/WiFi PHY, where both transmit and receive chains are illustrated. In this implementation, the transceiver can be configured as a standalone WiMax or standalone WiFi at any one time, because they are using the same baseband PHY blocks in different configuration.

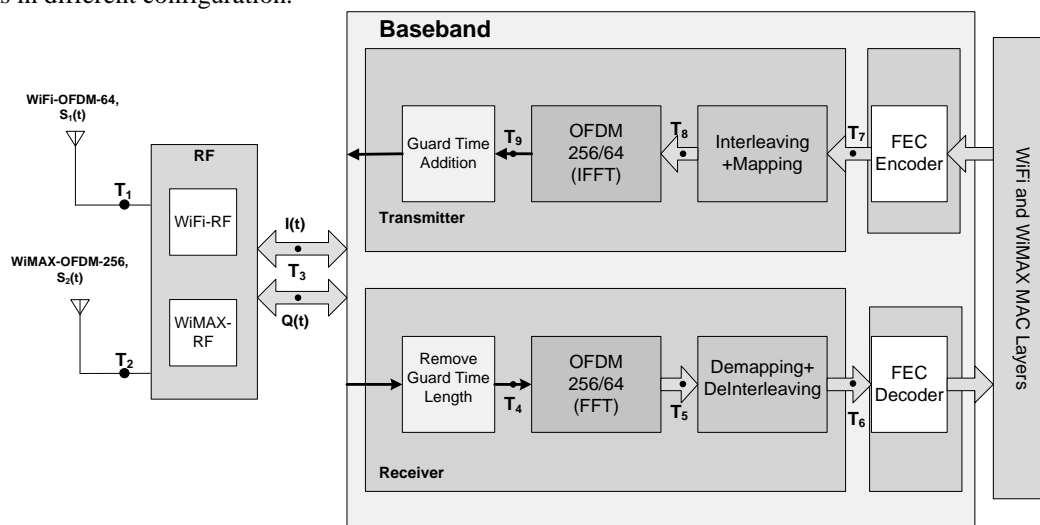

Figure 1, WiFi-WiMax PHY Layer Block Diagram

The following steps mathematically explain how a WiFi signal $S_1(t)$ or a WiMax signal $S_2(t)$ is processed in the proposed W2BC for the receiver part only. At the antennas of Figure (1), the WiFi-OFDM-64 signal, $S_1(t)$, is being carried on a 2.4GHz or a 5GHz carrier frequency using 64 OFDM samples, while the WiMax-OFDM-256 signal, $S_2(t)$, is being carried on 3.5GHz carrier frequency using 256 OFDM samples. The Test Points (T_1 - T_9) will be used to track the signal through the following PHY stages:

1. At the first test point T_1 , $S_1(t)$ is received by the WiFi antenna then passed on to the WiFi-RF part for processing to a baseband signal. The equation of the $S_1(t)|_{T_1}$ (or $S_1(t)$ at T_1) is:

$$S_1(t)|_{T_1} = \text{Re} \left\{ e^{j2\pi f_{c1}t} \cdot \sum_{\substack{k=-26 \\ k \neq 0}}^{+26} C_k \cdot e^{j2\pi k \Delta f_1 (t - T_{g1})} \right\}$$

2. At T_2 , $S_2(t)$ is received by the WiMax antenna then its RF shall produce the baseband signal. Therefore, the equation of the $S_2(t)|_{T_2}$ (or $S_2(t)$ at T_2):

$$S_2(t)|_{T_2} = \text{Re} \left\{ e^{j2\pi f_{c2}t} \cdot \sum_{\substack{k=-100 \\ k \neq 0}}^{+100} C_k \cdot e^{j2\pi k \Delta f_2 (t - T_{g2})} \right\}$$

3. By removing the carrier signal, therefore at T_3 ;

$$S_1(t)|_{T_3} = \sum_{\substack{k=-26 \\ k \neq 0}}^{+26} I_k \cdot \text{Cos}(j2\pi k \Delta f_1 (t - T_{g1})) + j \cdot \sum_{\substack{k=-26 \\ k \neq 0}}^{+26} Q_k \cdot \text{Sin}(j2\pi k \Delta f_1 (t - T_{g1}))$$

$$S_2(t)|_{T_3} = \sum_{\substack{k=-100 \\ k \neq 0}}^{+100} I_k \cdot \text{Cos}(2\pi k \Delta f_2 (t - T_{g2})) + j \cdot \sum_{\substack{k=-100 \\ k \neq 0}}^{+100} Q_k \cdot \text{Sin}(2\pi k \Delta f_2 (t - T_{g2}))$$

4. At the T_4 stage, the guard-time length is removed from the signals $I(t)$ and $Q(t)$ before the FFT stage. Adding guard time (cyclic prefix) to the transmitted signal is to create an "Inter Symbol Interference free channel (ISI-free)". Cyclic Prefix provides multipath immunity and tolerance for "symbol time sync errors" [14]. For the WiFi-OFDM-64 signal the guard time is $T_{g1} = 0.8 \mu\text{s}$ which represents adding an extra 16 symbols as a cyclic prefix, while for the WiMax-OFDM-256 signal, the guard time is $T_{g2} = 8 \mu\text{s}$, which represents an extra 64 symbols as a cyclic prefix. Therefore,

- a) For WiFi,

$$I_1(t)|_{T_4} = \sum_{\substack{k=-26 \\ k \neq 0}}^{+26} I_k \cdot \text{Cos}(2\pi k \Delta f_1 (t)) \quad \text{and} \quad Q_1(t)|_{T_4} = \sum_{\substack{k=-26 \\ k \neq 0}}^{+26} Q_k \cdot \text{Sin}(2\pi k \Delta f_1 (t))$$
- b) For WiMax,

$$I_2(t)|_{T_4} = \sum_{\substack{k=-100 \\ k \neq 0}}^{+100} I_k \cdot \text{Cos}(2\pi k \Delta f_2 (t)) \quad \text{and} \quad Q_2(t)|_{T_4} = \sum_{\substack{k=-100 \\ k \neq 0}}^{+100} Q_k \cdot \text{Sin}(2\pi k \Delta f_2 (t))$$

5. At the T_5 stage, the IQ signals (one OFDM Symbol) are transformed from time domain to frequency domain using Fast Fourier Transforms. The FFT block generates two vectors: I-vector and Q-vector with either 64 or 256 length each. The combination of I and Q vectors represent a single OFDM symbol. At this point the IQ-vectors (data) contain complex numbers.

- (a) For WiFi, $I = [I_1, I_2, I_3, \dots, I_{64}]$ and $Q = [Q_1, Q_2, Q_3, \dots, Q_{64}]$,
- (b) For WiMax, $I = [I_1, I_2, I_3, \dots, I_{256}]$ and $Q = [Q_1, Q_2, Q_3, \dots, Q_{256}]$,

From the IQ-vectors, the data subcarrier indices are selected and passed on to the IQ de-mapping for demodulation, dropping the other subcarrier indices in the process (DC, Pilot and Guard bands). W2BC is designed to deal with those different indices and also reconstruct the data from the IQ-vectors whether it is WiFi or WiMax.

6. At T_6 , each IQ symbol is converted to a binary number. The number of bits per symbol is determined by knowing the modulation type that has been used for the current OFDM symbol. The numbers of bits per symbol are equal to 1, 2, 4 or 6 bits per symbol if the modulation type is BPSK, QPSK, 16QAM, or 64QAM respectively. For instance, if the current OFDM symbol has been sent using 16QAM modulation type, then each C_k (where $C_k = I_k + j.Q_k$) is converted to 4 bits binary number. Therefore, a full IQ-vector (one OFDM symbol) generates bits as an input vector to the Forward Error Correction (FEC) block. The WiMax and WiFi technologies use the “Reed Solomon block code” and “Viterbi convolution code”, [11], [12].

4. Simulation and Results

A closed-loop Simulink model representing the mathematical derivation of the W2BC (for both transmit and receive chains) as well as a noise channel (AWGN), has been designed and shown in Figure (2). MATABL is then used to simulate various static and dynamic test-benches based on real-world scenarios.

The test scenarios are designed to prove that the functionality and Quality of Service (QoS) (including data throughput (Bit Error Rate (BER) at various Signal to Noise Ratio (SNR)) and WiMax-WiFi switching performance) are maintained to the same standard as that of stand-alone WiMax and/or WiFi transceivers. During roaming, the instructions for association/re-association of the mobile device as it switches from one network to another (e.g. WiFi to WiMax, WiFi to a different WiFi, etc.) are decided in the upper layers. Therefore, all measurements are calculated for the PHY activities only, and are based on the simulation model of W2BC. Also, it was important to simulate a “seamless connectivity” scenario (where for example, the mobile device is downloading a live data stream) to prove that W2BC will not lose any of the data irrespective of the number of network switching during this communication.

4.1 W2BC Simulation Model Description

The W2BC mathematical derivation was described in the section (3). This model is transformed to simulation model using MATABL/Simulink.

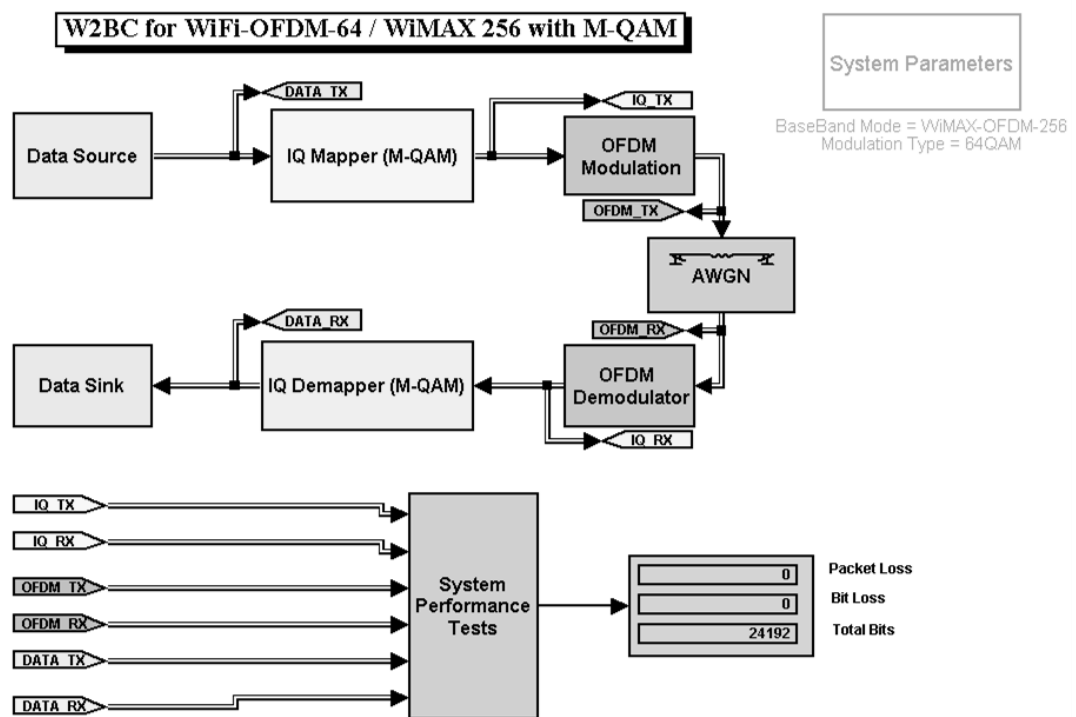

Figure 2, Simulink Model for the W2BC

Figure (2) shows a block diagram of this W2BC Simulink Model. This model represents both the receiver and the transmitter baseband functions, linked by a block of Additive White Gaussian Noise (AWGN) function to form a channel for this closed-loop system.

- The “data source” block contains integer vectors to represent digital data out of an ADC before quantisation. The vector length for the WiMax signal is 192 samples (representing one WiMax OFDM symbol), and for WiFi signal 48 samples (representing one WiFi OFDM symbol).
- The “IQ mapper (M-QAM)” and the “IQ Demapper (M-QAM)” blocks transform the sample vectors to IQ data and vice-versa, based on the modulation type selected by the upper layers (M can be set to equal 1 for BPSK, 2 for QPSK, 4 for 16QAM, or 6 for 64QAM modulation types). The actual IQ-Map values are based on the IEEE WiMax and WiFi standards.
- The “OFDM Modulation” block performs the IFFT, adds zero padding, and adds cyclic prefix functions, while the “OFDM demodulation” block performs the reverse of these functions. i.e. FFT, removes zero padding and removes cyclic prefix.
- The AWGN block acts as a channel between the receiver and transmitter chains. It contains a mathematical model of the channel where “the only impairment to communication is represented by a linear addition of wideband, or white noise with a constant spectral density, (expressed as watts per hertz of bandwidth) and a Gaussian distribution of amplitude” [15]. It allows various SNR values to be selected to enable boundary conditions testing. By the way, for the purpose of testing the W2BC implementation model, it does not matter which channel model is used. This is because measurement of the switching time during the reception/transmission process is not affected by the channel model. i.e. if there are errors due to the noise channel, then the FEC and the higher layers will deal with it.
- The “Data Sink” block gathers the transmitted data in integer vector format similar to that produced by the “data source” block.
- The “test point” probes represent signal status at these points. These probes are for DATA_TX, IQ_TX, OFDM_TX, OFDM_RX, IQ_RX and DATA_RX.
- The “system Parameters” block is a dummy block to host the values of the configuration parameters. See Table (3) for the detailed parameters and their values. Figure (2) is showing this block when the configuration is WiMax-OFDM-256 with 16-QAM modulation type.

4.2 Static Tests

The static tests verify that the W2BC functions correctly as per the IEEE standards. See Sections (4.2.1) and (4.2.2) for details of these tests where, to achieve full compliance with the standards, the BER has to be evaluated across SNR values ranging from 1 up to 25dB. Obviously, for the standalone WiMax or WiFi transceivers, operating at higher modulation rates at low SNR shall result in the worst transmission BER. Based on these static tests, the W2BC performance (BER vs. modulation rates) was also compared to off-the-shelf WiMax and WiFi products from Atmel, Freescale and Intel listed in Table (2).

Table 2, Commercial WiMax and WiFi chipsets

Technologies	Chipsets Part –No.	Released Documents
WiMax	Atmel -ATM86RF535A	DataSheet-2006, [16]
WiFi	Freesacle-LP1071	DataSheet-2005, [17]
WiMax-WiFi	Intel-622ANXHMW	Specifications -2009, [6]

4.3 WiMax Static Test

This static test is to establish the behaviour of the W2BC model (in terms of resulting BER) when it is subjected to various SNR setting using various modulation techniques. The simulator then determines the BER value for each test by comparing the transmitted and received data bit by bit at the DATA_TX and DATA_RX probes. For each modulation type, 100 WiMax-OFDM symbols (1920 bits) are transmitted and received for each SNR setting. In this test, the size of the transmitted/received data, for each modulation type, is 6 MB. As shown in Figure (3), the high modulation coding (bit/sample), like 64-QAM with SNR=5 dB, the resulted BER is very high and approaches 95%. However, this BER is reduced to 5% with the BPSK modulation. Therefore, the BER is inversely proportional with SNR, and the BER is highly dependant on the used modulation type. After comparing the result in Figure (3) with the [12] chapter 8 page 692 and [14] chapter 3, page 106, it confirms that the W2BC model (WiMax part) works correctly in a standalone WiMax PHY mode. Furthermore, this data is compared to the performance of Atmel’s chip [16] and shown to be compatible with its performance as well.

4.4 WiFi Static Test

This static test follows the same procedure as the WiMax test described in (4.2.1). i.e. For the each modulation type, 100 WiFi-OFDM symbols (480 bits) are transmitted and received per one SNR (SNR between 0 and 25 dB), with the size of the transmitted/received data, for each modulation type, is 1.5 MB. Figure (4) shows the performance of W2BC and it conforms to the WiFi standalone standard detailed in chapter 20, page 317, in [11], as well as the Freescale WiFi chip, [17].

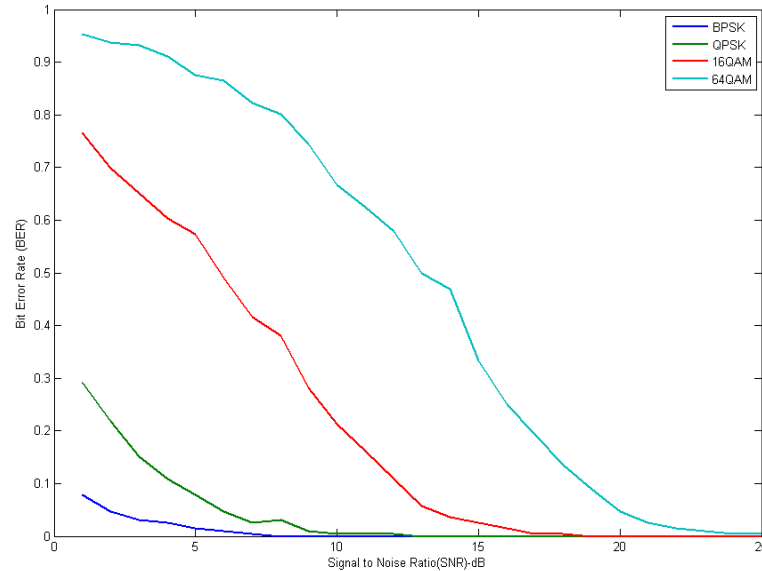

Figure 3, MATLAB results for W2BC static test showing BER Vs. SNR for WiMax-OFDM-256 in different modulation types (B/W=3.5MHz, Fc=3.5GHz, AWGN Channel)

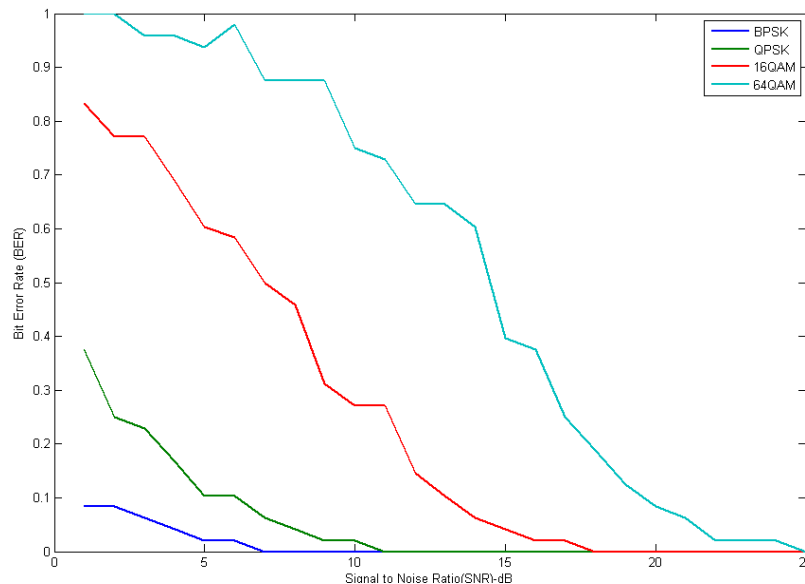

Figure 4, MATLAB results for W2BC static test showing BER Vs. SNR for WiFi-OFDM-64 in different modulation types (B/W=20MHz, Fc=2.4GHz, AWGN Channel)

4.5 Dynamic Tests

The W2BC offers configurability to the baseband-implementation block functions. This means real time switching between WiMax and WiFi configurations dependent on usage/requirements of the application. The instructions to switch from/to WiMax and/or WiFi are initiated from the upper layers. Figure (5) illustrates the test setup showing how the W2BC could be configured to switch to different modes as per the configuration Table (2). The actual time consumed to load up the configuration parameters from the configuration list together with the time to configure the W2BC from one configuration setup to another

(labelled "Switching Time" T_{wx} from WiMax and T_{wf} from WiFi) is shown in Table (3). Table (3) also shows the list of W2BC configuration parameters that are used for selecting any of the 8 possible modes.

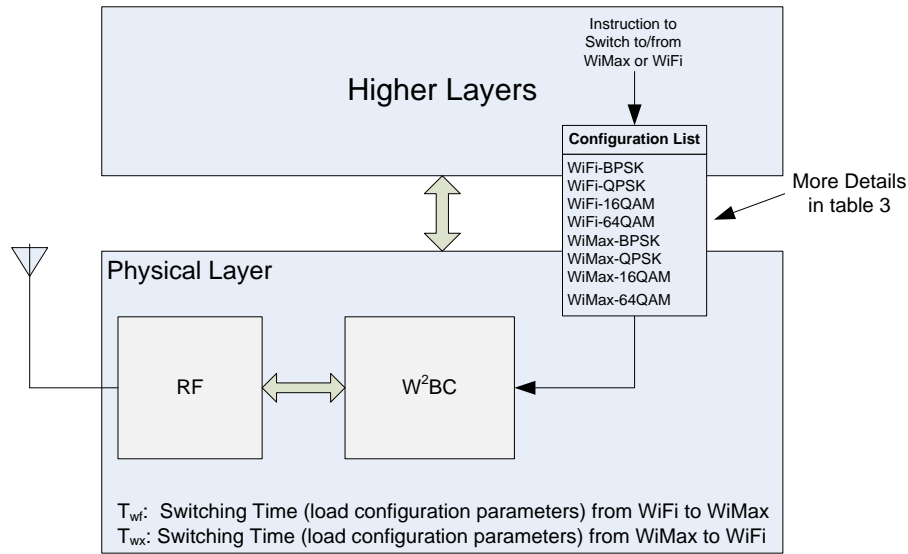

Figure 5, A block diagram of the test setup for the W2BC switching time (T_{wx} and T_{wf})

Table 3, Configuration Parameters for the W2BC to switch to/from WiMax and WiFi

Parameters	W2BC Configuration Parameters							
	WiFi-OFDM-64				WiMax-OFDM-256			
	BPSK	QPSK	16QAM	64QAM	BPSK	QPSK	16QAM	64QAM
M-QAM Bits	1	2	4	6	1	2	4	6
IQ-MAP	See IEEE Standards							
NFFT	64				256			
Data Sub-Carriers	48				192			
Cyclic Prefix indices	49:64, 1:64				193:256, 1:256			
Pilots Subcarriers indices	-7, -21, +21, +7				-88,-63,-38-13 +13,+38,+63,+88			
Data Subcarriers indices	-26:-22, -20:-8, -6:-1, +1:+6, +8:+20 +22:+26				-100:-89, -87:-64, -62:-39, -37:-14, -12:-1, +12:+1, +37:+14, +39:+62, +64:+87, +89:+100			
Guard Band Subcarriers indices	-32:-27, +27:+32				-128:-101, +101:+127			

The motivation behind the dynamic tests is to measure the switching times (T_{wx} and T_{wf}) in different real-world scenarios. The results of these tests are to prove if any data have been lost due to these switching actions. Note that, the switching time measurement is highly dependent on the simulator model and host processor speed. However, this will be dependent on the silicon technology/process that the PHY is manufactured.

4.6 Roaming between WiMax and WiFi basestation Tests

This test is designed to simulate a real world scenario of a W2BC device roaming/switching between various combination of WiFi and WiMax stations. To illustrate this, Figure (6) shows the W2BC device is roaming through 8 different WiMax and WiFi basestations, each of which is configured for a different modulation type. For the WiMax duty, the number of bits per one OFDM symbols is 192 bits and is 48 bits for the WiFi duty. The W2BC device will be downloading a data stream of a 1MBytes from a file while roaming. This scenario takes around 802.65 seconds to download and the resultant switching time measured for each region-change ranges between 1.7-2.5 msec.

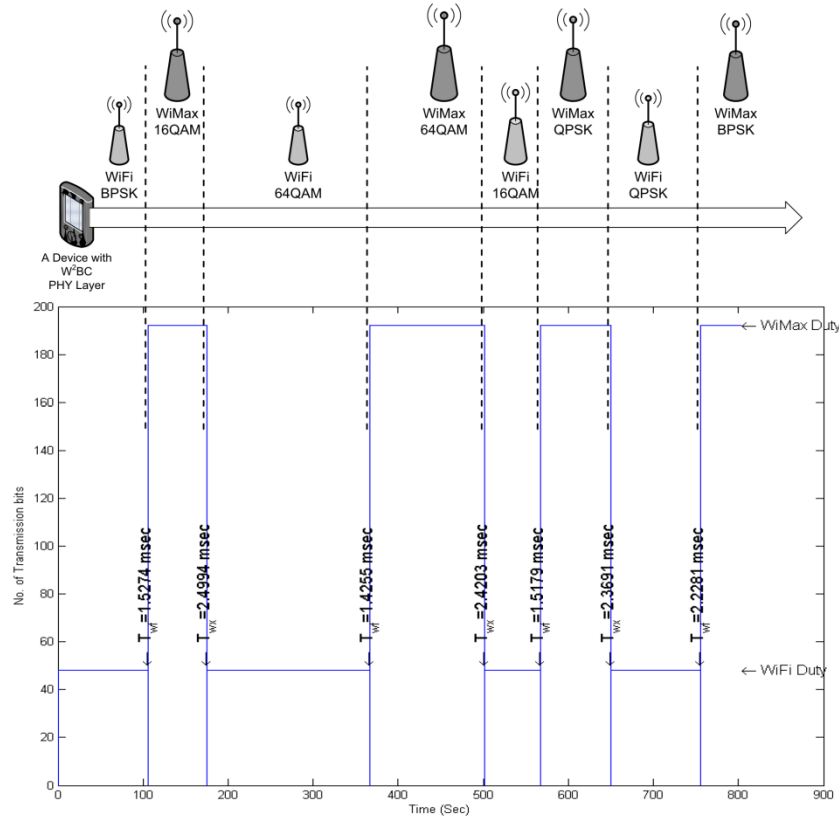

Figure 6, Test the W2BC switching time, through WiMax and WiFi, for 1.05Mbytes data stream at 15dB SNR

Figure (7) shows the resultant BER for this test but repeated for various SNR values. These errors are caused by the noise channel and not by the W2BC implementation. Obviously, the BER results show that errors are highly dependent on the SNR over the particular channel, for the four modulation types. This is expected result when compared to the specification of IEEE standards and also the performance of the commercial chipsets listed in Table (2).

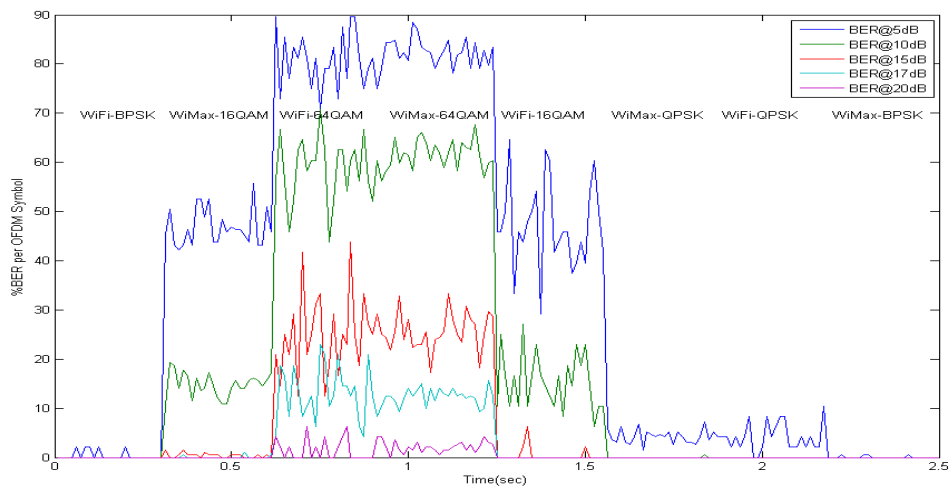

Figure 7, BER for SNR values (5, 10, 15, 17 and 20 dB)

4.7 Switching/roaming between various WiMax Test

In these tests, the same scenario of section (4.3.1) is repeated to measure the switching time while the W2BC device is roaming between various WiMax basestations, or while the W2BC device is switching between various modulation types while in the same WiMax region/basestation. Figure (8) and Figure (9) illustrates the measurements obtained for downloading a stream of 4.7Kbytes data. All results demonstrate the same switching times and behaviour of the W2BC.

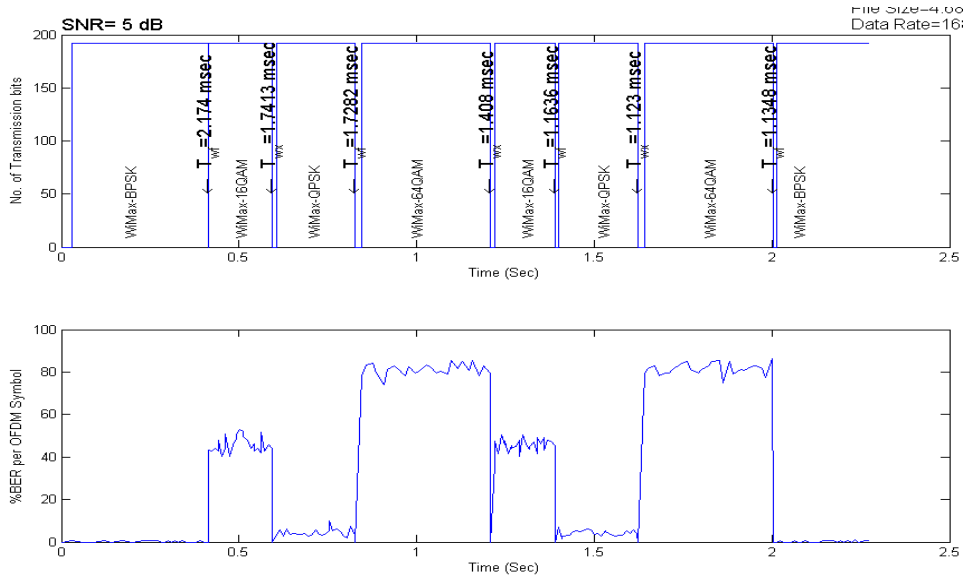

Figure 8, showing the W2BC switching time and BER, through WiMax, for a 4.7KB data stream at 5dB SNR

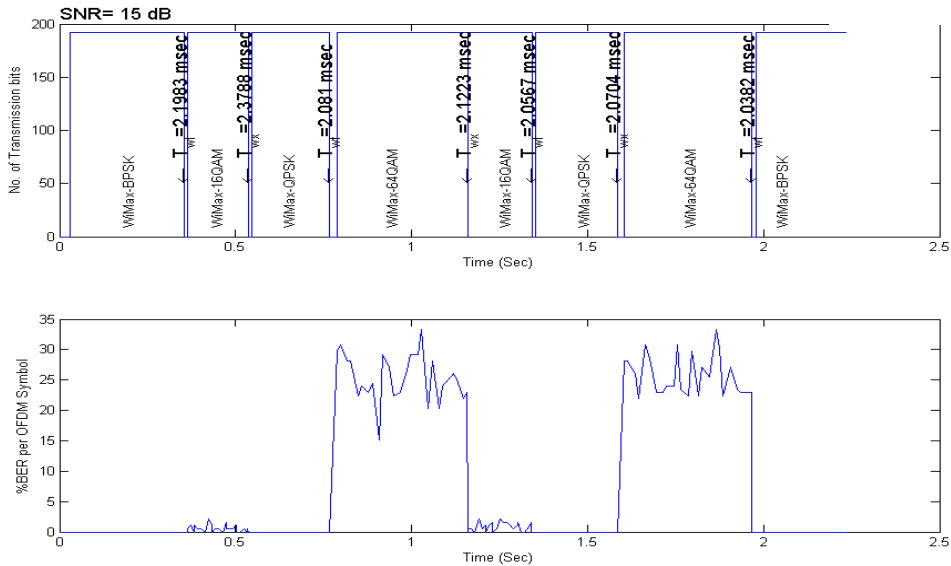

Figure 9, showing the W2BC switching time and BER, through WiMax, for a 4.7KB data stream at 15dB SNR

4.8 Switching between various WiFi basestations Test

In these test, the same scenario of section (4.3.1) is repeated to measure the switching time while the W2BC device is roaming between various WiMax basestations, or while the W2BC device is switching between various modulation types while in the same WiMax region/basestation. Figures (10) and (11) illustrates the measurements obtained for downloading a stream of 1.2Kbytes data. All results demonstrate the same switching times and behaviour of the W2BC.

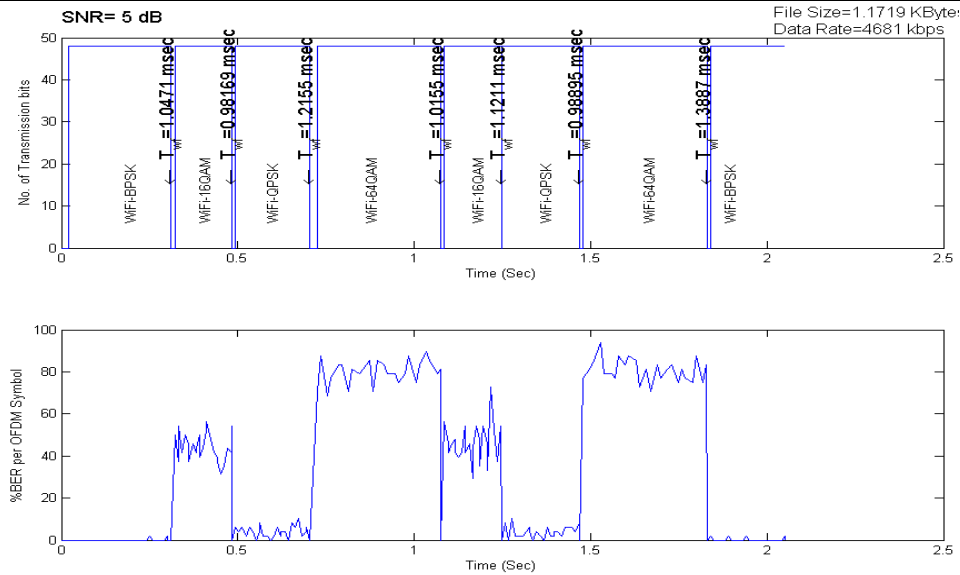

Figure 10, showing the W2BC switching time and BER, through WiFi, for a 1.2KB data stream at 5dB

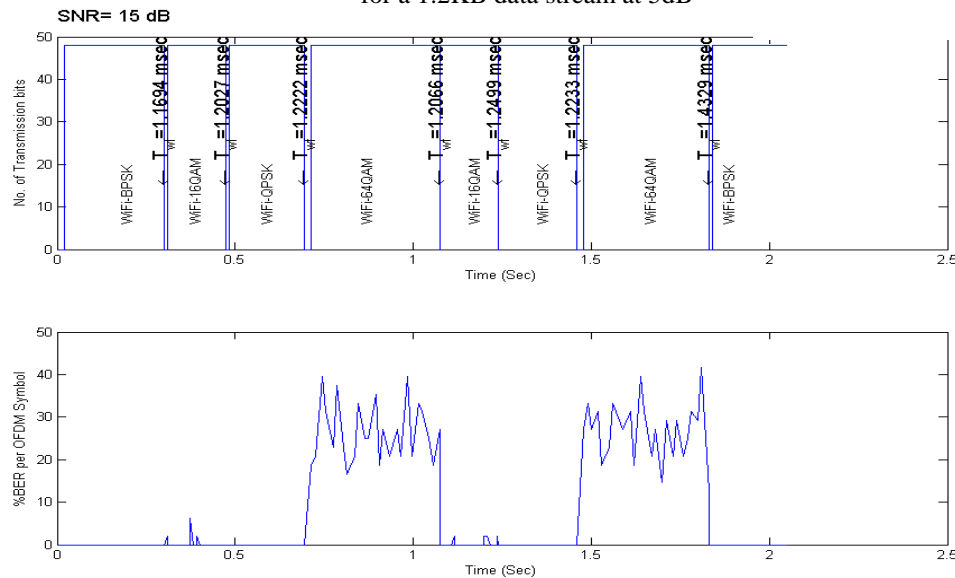

Figure 11, showing the W2BC switching time and BER, through WiFi, for a 1.2KB data stream at 15dB

5. Discussion and Conclusion

This research work proposes the W2BC approach that offers a novel implementation concept for convergence of the WiMax and WiFi technologies. The next step would be to implement the W2BC on silicon with the configuration control at the upper layers in software. A number of potential companies have been approached to sponsor this implementation. Unfortunately, slow deployment of WiMax has resulted in a number of the major companies pulling out of this market. Thus, no decision of sponsoring the silicon implementation has been reached thus far. The simulation model and test scenarios were, therefore, the most convenient available environment to prove the viability of the W2BC, and that it performs to the IEEE specification for standalone WiMax or WiFi transceivers as well as commercially deployed standalone products. The resulted W2BC average switching time ranges between 1.5msec and 2.5 msec. This time is less than the time of a standalone WiMax or WiFi frame (the standards specify 5 msec). This measured delay is of course relevant to the simulator's host processor environment, but it is expected that a dedicated silicon implementation will result in much faster switching time. In any case, an estimated overhead of <2% delay will be attributed to the W2BC switching time delay. i.e. it is expected that the W2BC switching time in the real-time implementation will be less than 2.5 msec.

Recently, a new single chip product has been announced by Intel-622ANXHMW [6]. This chip claims to support WiMax and WiFi standalone functionality on a single die, but no datasheets has been

released yet, despite many attempts to get it from Intel. It can be deduced, from the marketing flyer of this chip, that some kind of combined WiMax+WiFi baseband implementation exists either side-by-side or in a similar fashion to this W2BC proposal has been adopted. This chip can be regarded as evidence that this kind of convergence is commercially attractive and relevant to the deployment of near future wireless data/broadband communications.

In conclusion, W2BC achieves a compact baseband implementation of these two technologies with no impact on performance. Thus achieving much needed saving in silicon size, power and cost. It is estimated that sharing a single PHY layer for multiple technologies has resulted in reduction of the size of the baseband implantation, in terms of number of gates saved from a dual-PHY implementation, by reusing 85% of the gates for the second PHY implementation [1]. The baseband functions that have been made configurable in the W2BC implementation are clustered within the Cyclic Prefix, the FFT, the OFDM and the IQ-Mapping blocks. The W2BC concept can be expanded to cover mobile-WiMax (802.16e) OFDM-512, OFDM-1024 and so on.

REFERENCES

- [1]. Man Cheuk, N., Vijayaraghavan, M., Dave, N., Raghavan, G. and Hicks, J.: "From WiFi to WiMax: Techniques for High-Level IP Reuse across Different OFDM Protocols: Formal Methods and Models for Codesign", MEMOCODE 2007. 5th IEEE/ACM International Conference, 2007.
- [2]. Niyato, D. and Hossain, E.: "Wireless Broadband Access: Wimax And Beyond - Integration of WiMax and WiFi: Optimal Pricing for Bandwidth Sharing". IEEE Communications Magazine. May 2007, Vol. 45, 4, pp. 140-146.
- [3]. Behmann, Fawzi. Lincoln, NE.: "Impact of Wireless (WiFi,WiMax) on 3G and Next Generation-An initial Assessment". IEEE International Confrence for Electro Information Technology, IEEE Xplore, 2005. pp. 1-6.
- [4]. Jong-OK, H., Shigeno; A., and Yamaguchi-Obana, S.: "Airtime-based link aggregation at the co-existence of WiMax and WiFi". Indoor and Mobile Communication Journal, 2004, pp. 51-58.
- [5]. IEEE Std 802.16g.: "Information Technology – Telecommunication and Information Exchange between system – Local and Metropolitan Area Network –Specific Requirements – Part16: Air Interface for Fixed Broadband Wireless Access System". IEEE Standard Assocaition, 2009.
- [6]. Intel.: "Intel Centrino Advanced-N+WiMax 6250. USA". Intel Corporation, 2009. Marketing Flyer.
- [7]. IEEE 802.21.: "MIH Standard for Local and Metropolitan Area Networks: Media Independent Handover Services"., IEEE Standard Assocaition, 2008.
- [8]. IEEE Std 802.16.4, Task Group 4, "IEEE 802.16's Task Group 3 had been developing, under IEEE PAR 802.16b, an amendment to IEEE Standard 802.16 Air Interface for Fixed Broadband Wireless Access Systems. This portion of the amendment covers MAC Modificatio, IEEE 802.16 WirelessHUMAN TM Task Group 4, 2009.
- [9]. IEEE Std 802.11u, Task Group.: "Part11 amendment: Interworking with External Networks". IEEE 802.11, 2010.
- [10]. Hiertz, G. R., Denteneer, D., Stibor, L., Zang, Y., Costa, X. P., Walke, B.: "The IEEE 802.11 universe". IEEE Communications Magazine. Jan 2010, Vol. 48, 1, pp. 62-70.
- [11]. IEEE Standard 802.11n.: "Part 11: Wireless LAN Medium Access Control (MAC) and Physical Layer (PHY) Specification". 2010, IEEE LAN/WAN Std, p. 536.
- [12]. IEEE Standard 802.16.: "Part16: Air Interface for Fixed Broadband Wireless Access System".: IEEE Standard for Local Metropolitan Area Network, 2009.
- [13]. Zlydareva, O. and Sacchi, C.: "Multi-Standard WIMax/UMTS System Framework Based on SDR". IEEE Aerospace Conference. 2008, pp. 1-13.
- [14]. Jeffrey, G., Andrews, Arunabha, Ghosh and Rias, Muhamed.: "Fundamentals of WiMax: understanding broadband wireless networking". Texas : Prentice Hall, 2008.
- [15]. Goff, Hill: "The Cable and Telecommunications Professionals' Reference: Transport Networks". CRC Press, 2012.
- [16]. Atmel.: "WiMax Transceiver 802.16-2004".: Datasheet.: Atmel, 2006.
- [17]. Freescale.: "LP107: 802.11a/b/g Baseband System Solution". Arizona, USA: Freescale Semiconductor, Inc., Datasheet, 2005.

BIOGRAPHY OF AUTHORS

Dr Ihsan Lami,
School of Science, Medicine and Desntistry,
The University of Buckingham,
Buckingham MK18 1EG, UK

Dr Ali Al-Sherbaz
School of Science & Technology,
The University of Northampton, St Georges Avenue,
Northampton, NN2 6JD, United Kingdom